

**HEAT TRACING TEMPERATURE SWITCH
FOR ORDINARY AREAS**

Model **TF4X40**

Remote sensing bulb and capillary type

Description

The remote bulb and capillary type are used to sense the fluid media temperature.

The local mount types are used to sense ambient temperatures for freeze protection applications.

Caution: Do not use this switch for hazardous environments. Sensing bulb and probe must not exceed specified proof temperatures.

Installation

Caution: This switch should be installed by a trained service person.

Switch

Mounting: Switch may be mounted in any position.

Sensors: For heat tracing, install bulb toward the bottom of pipe or vessel, away from heat sinks and approximately 90° from the heat tracing cable. Always secure both bulb and capillary and wrap with proper insulating tape.

For ambient sensing, orient the probe for optimal ambient temperature sensing, away from heat sources or heat sinks.

Enclosure: Type NEMA 4X .

Enclosure temperature limits:
-30 °F to 140 °F (-34 °C to 60 °C).

Wiring

All electrical wiring must comply with local and national electrical codes.

Caution: Electrical rating must be within range stated on switch nameplate. Failure to stay within rating may result in damage to, or failure of electrical contacts.

Electrical

Rating: 22A at 125, 250, 480 VAC.

Electrical

Connection: Two #14 AWG wires 12 inches long.

Switch is wired normally open.

Testing of the Switch

Testing of the switch may be done before or after final installation. If bench tested, the switch should be re-tested when installed in the final application. Be sure switch can be tested without affecting other equipment. Check nameplates for electrical rating and circuitry (normally closed or normally open) of switch. Cycle switch a few times to check operation.

Set-Point Adjustment

Switch is factory set. Set-point is not user-adjustable. Switch contacts close at 40° ±4°F on decreasing temperature set-point.

Agency Approvals

 Underwriters Laboratories, Inc.
Temperature Indicating and Regulating
Equipment File No. E56247, Guide No. XAPX.

 Canadian Standards Association listed for
Temperature Indicating and Regulating
Equipment File No. LR34555,
Guide No. 400-E-O, Class 4813.

Troubleshooting

Warning: Disconnect electrical power supply to switch before removal or inspection. Failure to observe this warning could result in serious injury or switch damage.

Important: The switch is not field-repairable. In case of damage, replace entire switch.

Causes of improper operation:

1. Incorrect electrical connection: check leads to switch. Be sure they are properly connected. See "Wiring" section for circuitry color code.
2. Faulty control circuit: check electrical power supply to switch. Check for loose or blown fuses, open circuited or grounded wires, loose connections at the switch
3. Incorrect temperature: check temperature in system. Temperature must be within range specified on nameplate.
4. Excessive vibration: check for temperature fluctuations in system. Check switch mounting and be sure there is no excessive vibration.

If the operation of the switch cannot be corrected by the above means, consult factory or authorized factory representative.

For service or ordering information

Consult factory or authorized factory representative. Specify full catalog number (with any optional modifications or factory set-point) as shown on part number code.

Warranty

All products of the company are sold and all services are offered subject to the company's standard conditions of sale.

TEMPERATURE RANGE

SWITCH NUMBER	FIXED SET POINT	BULB SENSOR EXPOSURE LIMITS (PROOF)
TF4X40	40 °F (4.4 °F) DECREASING	-40 TO 160 °F (-40 TO 71 °C)

WIRE CODE

Purple = Common

Blue = Normally Open

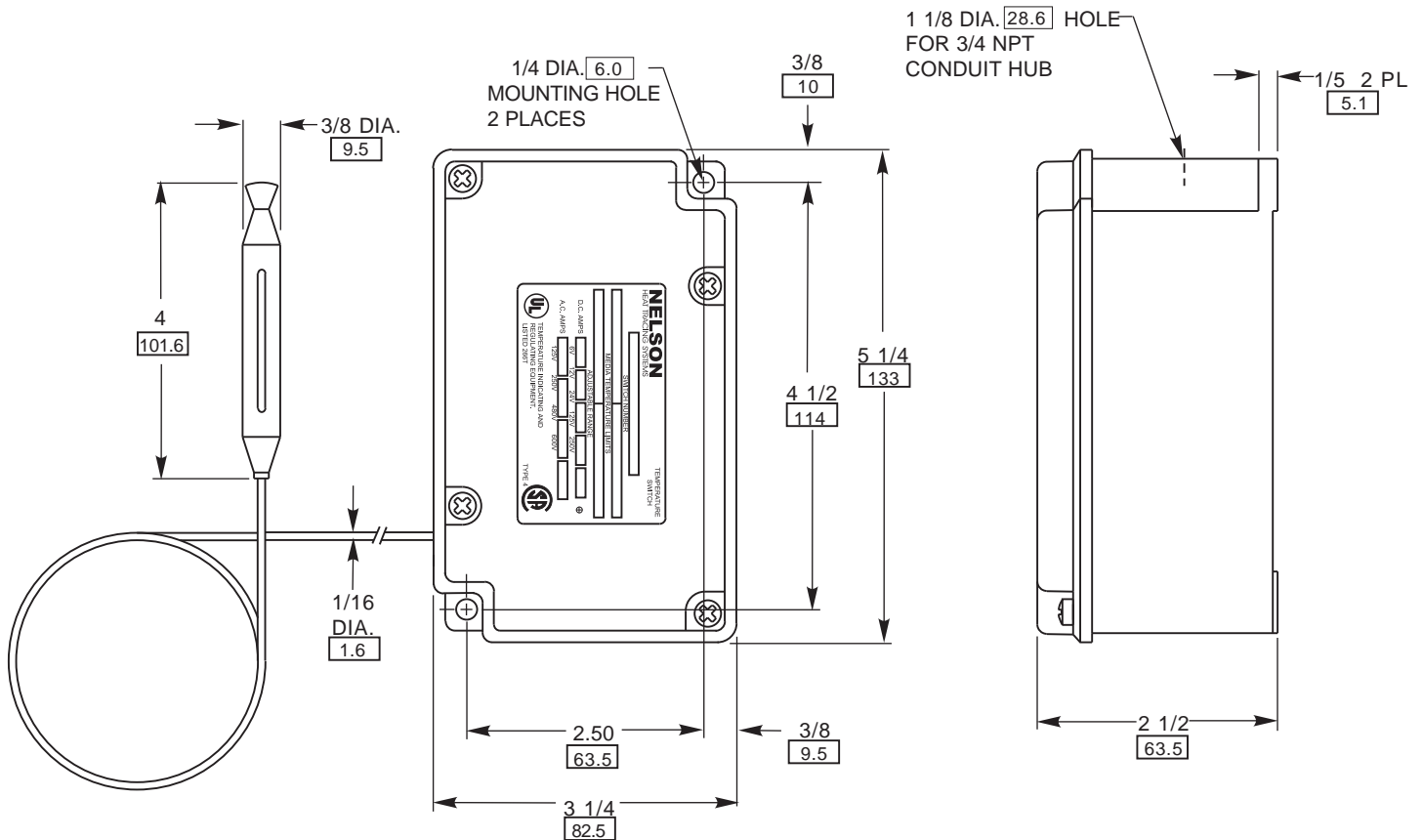

DIMENSIONS IN BOXES ARE IN MILLIMETERS

Installation Instructions

Installing the Thermostat

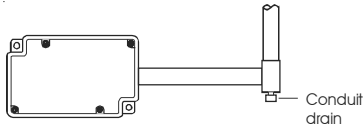

1. Verify that the thermostat is suitable for the area where it is to be installed.
2. Check the line voltage and the heat-tracing load to ensure that the thermostat ratings are not exceeded.
3. Mount the unit in a position that prevents condensation from draining into the enclosure from the connecting conduit, (see diagram at left).

Positioning (Ambient)

4. Mount ambient-sensing units in the area exposed to the coldest temperature and most wind. Do not mount on the side of a warm building on in a location that is exposed to warm air currents or direct sunlight.

Positioning the Sensor Bulb (Line Sensing)

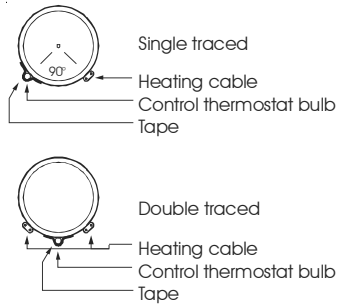

5. Position the bulb in the lower quadrant of the pipe as shown in the diagrams to the left. Place the bulb at least three feet from pipe supports, valves, or other heat sinks; protect the capillary from kinks or bends less than 1/2 inch in radius.
6. Tape the bulb firmly to the pipe with aluminum tape, making sure there is no air space between the bulb and pipe. Do not overlap the bulb and heating cable with the same piece of tape.

Wiring

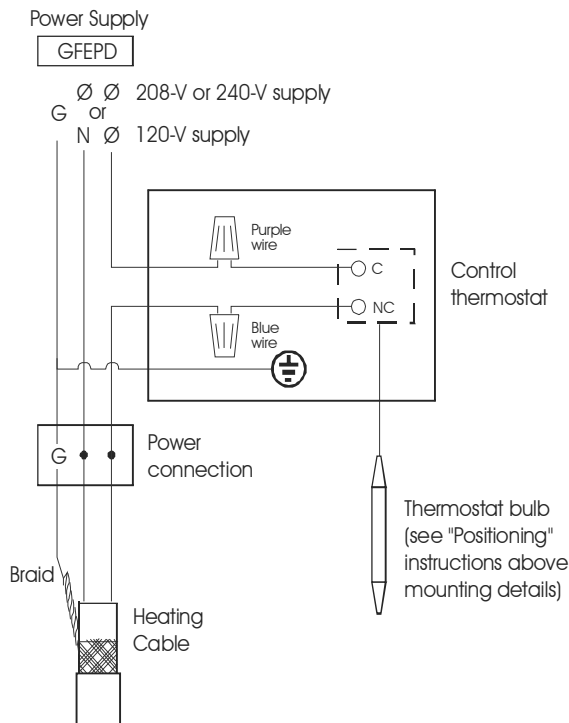

Figure 1. Heat-tracing control

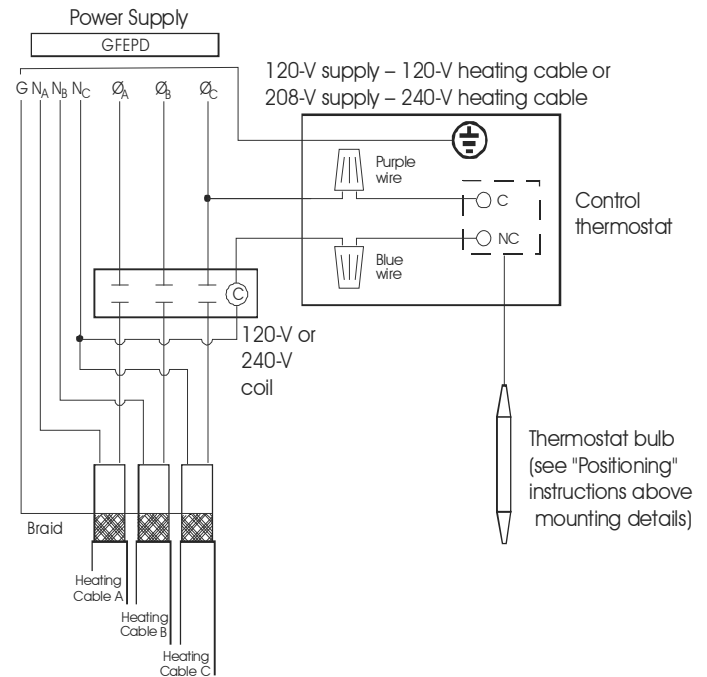

Figure 2. Contactor control

For switching heat-tracing loads greater than 22 A or switching multiple heat-tracing circuits.

Important: All information, including illustrations, is believed to be reliable. Users, however, should independently evaluate the suitability of each product for their particular application.