

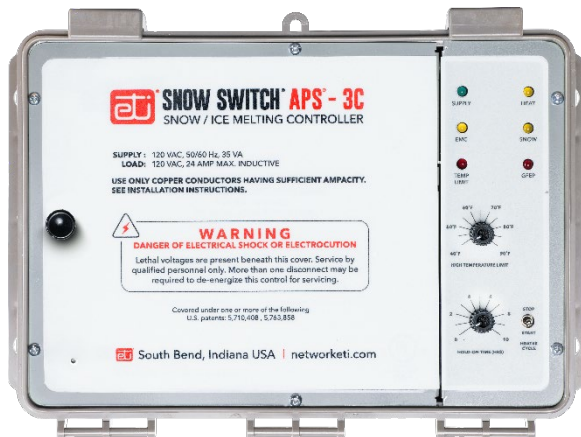

# WarmlyYours

## Radiant Heating Systems

Experts since 1999



## Automatic Snow/Ice Melting System Control Panel **MODEL SCP-120 (APS-3C) SNOW SWITCH**

### SAFETY

Make all electrical connections in compliance with the National Electrical Code (NFPA 70) and local electrical code. If you have questions concerning the installation or application, contact Customer Service.

### SÉCURITÉ

Effectuez toutes les connexions électriques conformément au Code électrique National (NFPA 70) et au code électrique local. Si vous avez des questions concernant l'installation ou l'application, contactez le Service Client.

products can be found in Acrobat (pdf) format to view online or to print. This is to assist you in installing and using our products to the best effect possible. If you have any comments about this or any other product from ETI, please contact us.

### DES INFORMATIONS SUPPLÉMENTAIRES

Plus d'informations sont régulièrement mises à disposition via notre site Web, [www.networketi.com](http://www.networketi.com). veuillez nous rendre visite en ligne pour des fiches techniques, des manuels, des livres blancs, des articles techniques, et plus encore. La version la plus récente et la plus à jour de ce manuel et de tous les autres pour nos produits se trouve au format Acrobat (pdf) pour être affichée en ligne ou imprimée. Ceci est pour vous aider à installer et à utiliser nos produits au meilleur effet possible. Si vous avez des commentaires sur ce produit ou tout autre produit D'ETI, veuillez nous contacter.

### **PILOT DUTY**

The APS-3C Snow Switch is designed for Pilot duty application but can also be used for direct loads up to 30 amps resistive.

### **PILOTE DEVOIR**

Le commutateur de neige APS-3C est conçu pour l'application de devoir pilote mais peut également être employé pour des charges directes jusqu'à 30 ampères résistifs.

### **ABNORMAL ODOR OR SMOKE**

In the event of smoke or a burning or abnormal odor, immediately interrupt power to the unit by turning off the circuit breaker protecting the unit.

### **ODEUR OU FURNÉE ANORMALE**

En cas de fumée ou de brûlure ou d'odeur anormale, coupez immédiatement l'alimentation de l'unité en fermant le disjoncteur protégeant l'unité.

### **ELECTRICAL SHOCK / FIRE HAZARD**

Any installation involving electric heater wiring must be grounded to earth to protect against shock and fire hazard. Suitable ground fault detection and interrupting systems must always be in use to reduce shock and fire hazard and to protect equipment. Electric wiring to heating elements must be installed in accordance with National Electrical Code (NEC)/ Canadian Electrical Code requirements, as well as all other local and applicable electrical codes and any third party standards. This product is intended for commercial and industrial applications. Follow the installation instructions contained in this manual and those provided by the heater manufacturer. Size the circuit breaker appropriately for the expected load and inrush current. The maximum rated current for the APS-3C is 30 amps with resistive load. Heater loads and their controls should not share a circuit branch with other types of equipment. A shared circuit may result in electromagnetic interference that can affect system operation. Make certain that the heater shield is

properly grounded. Failure to do so may result in damage to the equipment or fire. Following installation and prior to beginning system operation, refer to and perform the Post-Installation Test described in this manual.

### **RISQUE DE CHOC ÉLECTRIQUE / D'INCENDIE**

Toute installation impliquant un câblage de chauffage électrique doit être mise à la terre pour se protéger contre les chocs et les risques d'incendie. Des systèmes appropriés de détection et d'interruption des défauts à la terre doivent toujours être utilisés pour réduire les risques de choc et d'incendie et protéger l'équipement. Le câblage électrique des éléments chauffants doit être installé conformément aux exigences du Code national de l'électricité (NEC) / du Code canadien de l'électricité, ainsi qu'à tous les autres codes électriques locaux et applicables et à toute norme tierce. Ce produit est destiné aux applications commerciales et industrielles. Suivez les instructions d'installation contenues dans ce manuel et celles fournies par le fabricant de l'appareil de chauffage. Dimensionnez le disjoncteur en fonction de la charge et du courant d'appel attendus. Le courant nominal maximum pour le APS-3C est de 30 ampères avec une charge résistive. Les charges de chauffage et leurs commandes ne doivent pas partager une branche de circuit avec d'autres types d'équipement. Un circuit partagé peut entraîner des interférences électromagnétiques qui peuvent affecter opération Système. Assurez-vous que le blindage du radiateur est correctement mis à la terre. Ne pas le faire peut endommager l'équipement ou provoquer un incendie. Après l'installation et avant de commencer le fonctionnement du système, reportez-vous et effectuez le test de post-installation décrit dans ce manuel.

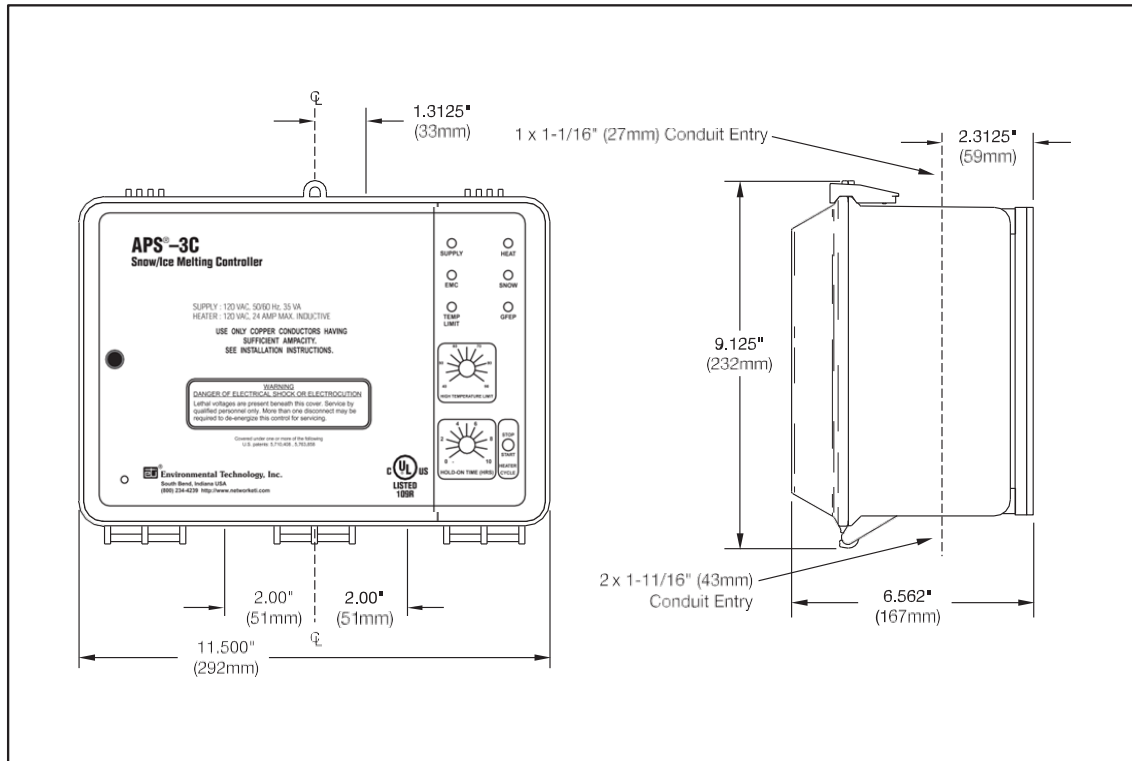

FIGURE 1. APS-3C Dimensional

## INTRODUCTION

The APS-3C Series Snow Switch Control, when used with compatible ETI sensors, automatically control snow and ice melting systems, ensuring complete melting for minimal operating costs. Typical applications are pavement, sidewalk, loading dock, roof, gutter, and down spouts.

APS-3C Controller improves upon and extends the features of previous models while maintaining backwards compatibility. The new APS 3C model is interchangeable with earlier APS models to ensure the continued long life of existing systems.

The APS-3C is available for 120 and 208-240 VAC and is optimized for inductive loads up to 24 amps, ideal for use in hydronic or steam systems in a pilot duty configuration or with customer systems that provide a relay interface.

APS-3C models provides a relay dry contact closure interface for use with a BMS (Building Management System). This feature can be used for general purpose remote control, annunciation of alarms and other advanced applications.

The APS 3C can also be controller remotely by a RCU-3 Remote Control Unit.

All sensor and communications wiring is NEC Class 2. This simplifies installation while enhancing fire and shock safety. **WARNING:** Do not over-tighten the Class 2 terminal block screw as this can result in an open/intermittent connection. The APS-3C can interface with up to six sensors from the ETI snow sensor line of products. More sensors provide superior performance by better matching the controller to site performance requirements.

## ENVIRONMENTAL INTERFACES

The APS-3C determines when to start heater operation by monitoring the signals produced by up to six ETI sensors, paralleled together using a 3-wire bus. All sensors are Class 2 low voltage for safety reasons. Available sensors include:

- SIT-6E Pavement Mounted Snow and Ice Sensor
- SNOW OWL Aerial Snow and Ice Sensor
- GIT-1 Gutter Snow and Ice Sensor

When used either alone or in combination, these sensors accurately determine whether snow and ice melting is required. If snow and/or ice is present, these sensors will provide the signal required to control your snowmelt system.

Sensors measure ambient temperature and detect moisture in any form. Snow, sleet, freezing rain, etc., is assumed if moisture is present at temperatures below 38°F (3.33°C). Beginning heater operation at temperatures slightly above freezing is essential to meeting customer expectations. It takes a long time for snow to melt at 34°F.

Using several sensors improves snow melting effectiveness by compensating for environmental variations. Consider a typical pavement snow and ice melting system. Vehicular and pedestrian traffic in commercial environments often expose the pavement to tracked slush and blowing or drifting snow. Because refreezing could create a hazardous situation, these hazards must be cleared. The solution is to combine several SIT-6E Pavement Mounted Snow and Ice Sensors in expected pedestrian and vehicular pathways, along with a SNOW OWL Aerial Snow and Ice Sensor placed high in an open, unobstructed location, exposed to falling snow. One or more additional SIT-6E sensors might be needed in areas subject to drifting and blowing snow and/or melt water run-off and refreezing.

The first sensor detecting freezing precipitation calls for snow melting. The last sensor detecting frozen precipitation signals the APS Control Panel that precipitation has stopped.

Sensors employ a heated interdigitated grid for moisture detection. Heat melts frozen precipitation to form water which is a better conductor of electricity. Circuits detect water as a change in resistance between the fingers of the interdigitated grid. The temperature of the moisture sensor is regulated electronically.

Each sensor has its own microcontroller for signal processing, logic and control. This enables the use of a simple 3-wire bus to connect sensors with the Control Panel. Extension wire function and colors follow:

- Supply (Red)
- Signal (White)
- Ground (Black)

Sensors are wired together in parallel in a “wired OR” configuration. That is, red to red, white to white, and black to black. When several sensors are connected in parallel, any sensor asserting a ground on the signal conductor enables snow melting heater operation. No ground on the signal line indicates the absence of snow.

The APS-3C Controller includes a temperature sensor for measuring pavement slab or ambient air temperature. Its signal is used to provide an adjustable high limit thermostat function. This sensor, or a bypass resistor, is required for proper system operation. This feature is essential when using a potentially high temperature heater such as MI cable.

### HIGH LIMIT THERMOSTAT

The calibrated 40°F to 90°F (4°C to 32°C) high limit thermostat prevents excessive temperatures when using constant wattage and MI heaters. It also permits safe testing at outdoor temperatures too high for continuous heater operation. **The temperature sensor is included and must be connected to the system for proper operation.**

There are two DIP switch configurable operation modes for the high limit thermostat. See figure 6. The factory default operation mode uses the high limit thermostat as a slab temperature regulator, preventing heater operation at temperatures

above the High Temperature Limit setting. The optional operating mode uses the high limit thermostat as an ambient air sensor, preventing heater operation at temperatures above the High Temperature Limit setting until the temperature drops back to within the set limits. The details of operation in each mode are as follows:

#### **SLAB REGULATING THERMOSTAT MODE**

- High temperature causes unit to turn off heaters, if running, and to ignore any call for heater operation from the panel, RCU, or BAS.
- High temperature continues any hold-on cycle that was initiated before the high temperature condition. If the slab temperature drops within limits during the hold-on time, the heater will be turned back on.
- The Heater Cycle functions normally.

#### **AMBIENT TEMPERATURE THERMOSTAT MODE**

- High temperature causes unit to turn off heaters, if running, and to ignore any call for heater operation from the panel, RCU, or BAS.
- High temperature cancels any Hold-On cycle that was initiated before the high temperature condition.
- If the Heater Cycle switch is operated in a high temperature condition, the heater(s) will be turned on for a maximum of 30 seconds. A new Heater Cycle cannot be initiated for another two minutes after that.

#### **HOLD-ON TIME**

The adjustable Hold-On Timer provides three functions affecting heater operation. The Hold-On Timer is used to continue heater operation, to manually operate heaters, or to provide a limited heater cycle for testing.

During normal operation, the Hold-On Timer continues heater operation for an adjustable time period of up to

10 hours after snow stops. The additional operating time compensates for the fact that there may be insufficient power to both melt the snow as it falls and evaporate the resultant melt water.

After normal operation has ended, the Hold-On Timer provides a method for clearing tracked or drifting snow that did not fall on a sensor. This can be accomplished by either increasing the Hold-On Time or by manually toggling the heaters on for the Hold-On Time, independent of environmental conditions.

Lastly, the Hold-On Timer provides a method of safe heater testing, that is independent of environmental conditions. The high limit thermostat ensures that this is the case. In ambient mode, at ambient temperatures above the high limit, the manual Hold-On Time is reduced to 30 seconds. In pavement mode, at pavement temperatures above the High Temperature Limit, the heaters are disabled.

#### **INITIAL SETTINGS**

When first placing the system into service, the Hold-On Time should be set to an initial value; 3 to 5 hours is suggested as a starting point. If the heaters turn off before the snow is completely cleared and the melt water evaporated, increase the Hold-On Time by an hour or two. If the heaters operate for several hours after the pavement is clear and dry, decrease the Hold-On Time by an hour. Continue this process until satisfactory performance is achieved.

**The small amount of energy wasted by a slightly excessive Hold-On Time is secondary to complete snow clearing and melt water evaporation. Incomplete operation is not desirable because this can result in re-freezing melt water which creates a slippery ice film.**

#### **IF THE SYSTEM TURNS OFF TOO SOON**

If the system turns off before the pavement is clear and dry, toggle the heaters on using the Hold-On Time switch on the front panel. Repeat as many times as is necessary until the pavement is clear and dry. If the heaters remain operating after the pavement is clear and dry, terminate

the Hold-On cycle with the Hold-On Time switch. Normal operation resumes if it starts snowing during the Hold-On Time.

### ENERGY MANAGEMENT COMPUTER (EMC)INTERFACE

The APS-3C Controller interfaces with an BAS via relays. Inputs from the BAS include Override On, which causes heater operation, and Override Off, which inhibits heater operation. These functions are independent of weather conditions and the status of the Hold-On Timer. The interface provides five system status contact closures for the BAS including Supply, Snow, Heater, Alarm, and Temperature Limit.

Absent signals from the BAS, the APS Control Panel controls the heaters based on environmental conditions. Automatic snow melting control is the default condition of the system.

### APS-3C FRONT PANEL

The APS-3C has indicators, adjustments, and a switch for local control of the snow melting system. Indicators include LED lights for Supply, Snow, Heat, BAS, Temp Limit, and GFEP (**NOTE:** Ground Fault Equipment Protection is **NOT** available on the APS-3C even though there is an indicator light for it.). Adjustments provided allow for the calibrated adjustment of system Hold-On Time from 0 to 10 hours (or Off) and Temp Limit for the High Temperature Limit adjustment with a range of 40° to 90°F (4° to 32°C). The Heater Cycle toggle switch allows for the manual starting and stopping of a Heater Cycle.

Figure 2 shows the APS-3C front panel layout.

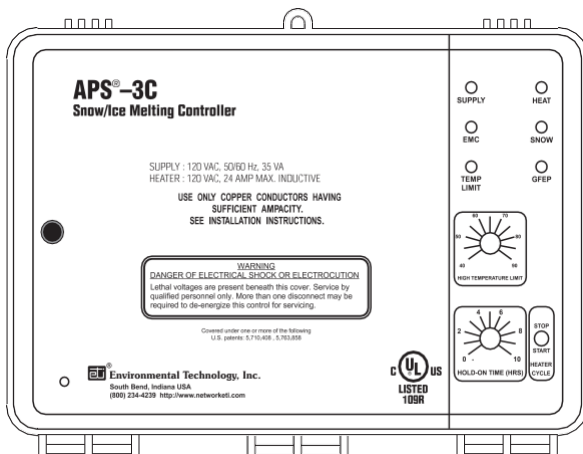

FIGURE 2. APS-3C front panel detail

### RCU-3 REMOTE CONTROL UNIT

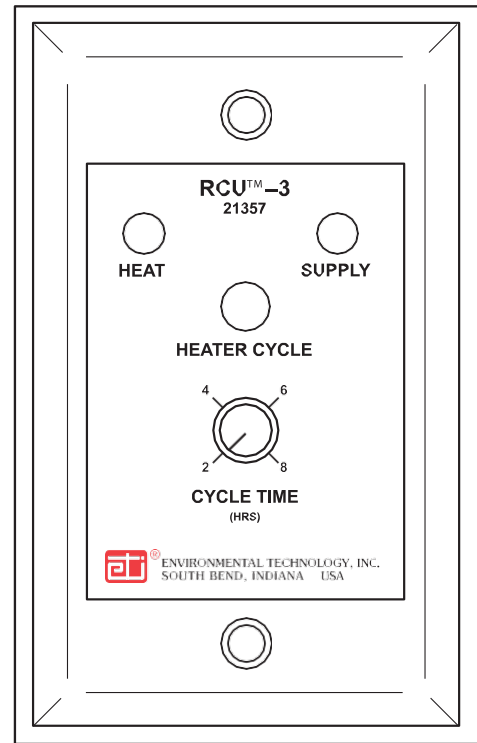

FIGURE 5. RCU-3

The RCU-3 Remote Control Unit is used with the APS-3C. It adds remote control and status display to the APS-3C control at a location convenient to personnel capable of observing snow melting system operation.



Snow , slush , or ice , whether alone or in combination , must contact at least one sensor to start melting . Heater operation continues until all sensors are dry. Depending on the rate of fall , snow density , wind velocity , power density , and other factors , heater operation must continue for a period of time after the last sensor dries off . Slush tracked by vehicle and pedestrian traffic , along with blowing and drifting snow , are problems that are hard to predict.



La neige la neige fondante ou la glace seule ou en combinaison doivent entrer en contact avec au moins un capteur pour commencer à fondre le fonctionnement de L'appareil de chauffage se poursuit jusqu'à ce que tous les capteurs soient secs en fonction du taux de chute de la densité de la neige de la vitesse du vent de la densité de la puissance et d'autres facteurs le fonctionnement de l'appareil de chauffage doit se poursuivre pendant un certain temps après le séchage du dernier capteur.

The cycle timer in the APS-3C begins when the last sensor dries off and continues for an adjustable period of up to 10 hours to keep the heaters operational until the pavement is completely dry. Otherwise, residual water could re-freeze and create a hazardous condition.

The RCU-3 provides a 2-, 4-, 6-, or 8-hour Cycle Time adjustment that is independent of the APS-3C cycle time. This allows treatment of the condition requiring an additional heater cycle as the exception rather than the rule in order to minimize energy use.

Operating the Heater Cycle switch operates heaters for the Cycle Time which is normally set for 2 hours. Operating the Heater Cycle switch during the cycle time stops the timer. If the pavement or ambient temperature exceeds the APS-3C High Temperature Limit setting, the heater duty cycle is reduced or disabled to prevent overheating. Status indicators include Supply and Heat. These perform the same functions as those on the APS-3C.

Figure 5 shows the RCU-3 layout.

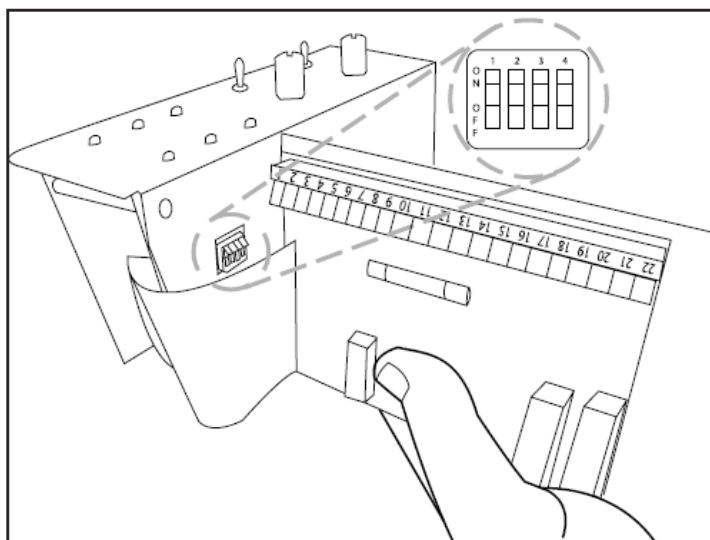

Figure 6. Location of DIP Switch

## OPERATION

### APS-3C

The snow melting system can be controlled and monitored either locally from the APS-3C itself or from two remote locations including:

- RCU-3 Remote Control Unit
- BAS

### LOCAL CONTROL FROM THE APS-3C

#### Indicators

- SUPPLY (green) shows that power is present.
- SUPPLY (green, blinking) means either the pavement temperature sensor is missing from the system or is not functioning. The pavement temperature sensor is included and must be connected to pins 10 and 11 for proper operation.
- SNOW (yellow) shows that there is a snow/ice signal originating from at least one of the SNOW OWL, GIT-1, and/or SIT-6E sensors attached to the system.
- HEAT (yellow) shows that there is a call for heat. This happens during snow and for the Hold-On Time thereafter or when the Heater Cycle switch is operated
- BAS (yellow) shows that the interfaced Building Automation System is presently overriding local system control.
- TEMP LIMIT (red) shows that either the pavement temperature is above the set High Temperature Limit and there is a call for heat or the ambient air temperature is above the High Temperature Limit setting. The APS-3C can be configured to monitor slab temperature or ambient air temperature but not both.

#### Adjustments

The Hold-On Time adjustment sets the time that heaters operate after snow stops. Doing this is necessary to make certain the pavement dries before heating ceases. This prevents refreezing. Try an initial setting of 3 to 5 hours. Increase, if necessary. Reduce with care as energy savings are being traded for an increased likelihood of refreezing.

- The High Temperature Limit adjustment sets the maximum deicing temperature.

#### **Switches**

- The Heater Cycle switch momentarily toggled down will start a manual Heater Cycle for the Hold-On Time setting or restart the Heater Cycle if one was in progress. Momentarily toggled up will cancel a Heater Cycle if one is in progress.

### **REMOTE CONTROL FROM THE RCU-3**

#### **Indicators**

- SUPPLY (green) shows that power is present.
- HEAT (yellow) shows that there is a call for heat. This happens during snow and for the Hold-On Time thereafter or when the heater cycle switch is operated.

#### **Adjustments**

- Cycle Time adjustment sets the time heaters will operate when the Heater Cycle switch is momentarily depressed at the RCU-3.

#### **Switches**

- Heater Cycle switch momentarily depressed will start a manual Heater Cycle for the Cycle Time setting. Momentarily depressed while heaters are being operated by a Hold-On Timer or during manual Heater Cycle will end the Heater Cycle. Heater operation during snow conditions cannot be canceled in this manner.

### **REMOTE CONTROL FROM THE EMC INTERFACE**

The EMC interface is identical on all of the APS "C" Series models. Please see the EMC section of this manual for interface details. Figure 20 pg 12.

### **ENERGY MANAGEMENT COMPUTER (EMC) INTERFACE**

The APS "C" Series provides an EMC interface to communicate with the EMC of building automation systems. The EMC interface provides 10 mA dry switch contacts for communicating status to the EMC or starting or stopping the system from the EMC. Refer to Figure 20 for EMC connections.

### **EMC INTERFACE OUTPUTS**

- Output Common
- HEAT indicates that there is a call for heat. This happens during snow and for the Hold-On Time thereafter or when the heater cycle switch is operated.
- SNOW indicates that there is a snow/ice signal originating from at least one of the connected SNOW OWL, GIT-1, and/or SIT-6E sensors attached to the system.
- ALARM - Indicates ground fault alarm.
- SUPPLY indicates that power is present.
- TEMP LIMIT indicates that either the pavement temperature is above the High Temperature Limit setting and there is a call for heat, or the ambient air temperature is above the High Temperature Limit setting. An APS "C" Series Control Panel can be configured to monitor slab temperature or ambient air temperature but not both. See figure 20 pg 12.

### **EMC INTERFACE INPUTS**

- OVERRIDE ON can be used to override an attached APS "C" Series Control Panel in order to turn heaters on. A normal contact closure will turn on heaters until operation is cancelled. If the EMC cycles the Override On relay on and off again within more than 32 milliseconds, but less than 300 milliseconds, the attached APS "C" Series Control Panel will begin a manual Heater Cycle and run for the Hold-On Time setting. See figure 20 pg 12.
- OVERRIDE OFF can be used to override an attached APS "C" Series Control Panel in order to turn heaters off. A normal contact closure will turn off heaters. If the EMC cycles the Override Off relay on and off again within more than 32 milliseconds, but less than 300 milliseconds, the attached APS "C" Series Control Panel will end a manual Heater Cycle. If both override on and Override off are closed (selected) the override off will take precedence.

## SPECIFICATIONS

All Specifications apply to APS-3C

### General

Area of use	Nonhazardous locations
Approvals	cUL type 873

### Enclosure

Protection	NEMA 3R
Cover attachment	Hinged polycarbonate cover, lockable
Entries	3 × 1-1/16" entries

Material	Polycarbonate
Mounting	Wall mounted

### Control

Supply	ETI PN 22470: 120 VAC, 50/60 Hz, 35 VA, ETI PN 22471: 208-240 VAC, 50/60 Hz, 35 VA,
Load	ETI PN 22470: 120 VAC, 24 amp max. inductive
Contact type	Form C Dry Contact Closures
Maximum Ratings	Voltage: 240 VAC Current: 24 amps
Heater hold-on timer	0 to 10 hours; actuated by snow stopping or toggle switch
System test	Switch toggles the heater contact on and off. If temperature exceeds high limit, heater cycles to prevent damage.

### Snow/Ice Sensors

Sensor type	Up to 6 sensors for APS-3C
Circuit type	NEC Class 2
Lead length	Up to 500' (152m) using 18 AWG 3-wire jacketed cable Up to 2,000' (609m) using 12 AWG 3-wire jacketed cable

### Energy Management Computer (EMC) Interface

Inputs	OVERRIDE ON (10 ma dry switch contact) OVERRIDE OFF (10 ma dry switch contact)
Outputs	SUPPLY (10 ma dry switch contact) SNOW (10 ma dry switch contact) HEAT (10 ma dry switch contact) HIGH TEMP (10 ma dry switch contact) ALARM (10 ma dry switch contact)

### Environmental

Operating temperature	-40°F to 160°F (-40°C to 71°C)
Storage temperature	-50°F to 180°F (-45°C to 82°C)

## INSTALLATION

### DIP SWITCH SETTINGS

#### Configuring the High Limit Thermostat

Dip Switch pin 3 is used to set the high limit thermostat operation to one of two possible operating modes:

- Off sets the high limit thermostat as a slab regulating temperature sensor.
- On sets the high limit thermostat as an ambient air sensor. Off is the factory default.

Figure 8 shows how to configure the high limit thermostat mode at the DIP switch.

#### FACTORY USE ONLY

DIP switch pin 4 is for factory use only. The use of pin 4, except by authorized personnel, may lead to improper operation of the APS-3C.

#### BYPASSING THE HIGH LIMIT TEMPERATURE SENSOR

If, for any reason, you need to operate the system without the High Temperature Limit Sensor (for troubleshooting or while waiting for a replacement sensor), Figure 21 you can temporarily replace the sensor with a 470K resistor. The resistor will allow the system to run as if the sensed temperature was 40°F (4.4°C).

Refer to Figure 22, for placement of resistor.

### DIP Switch Settings GFEP

DIP Switch Settings			
1	2	3	4
Off	On	----	----

60 mA

DIP Switch Settings			
1	2	3	4
On	Off	----	----

120 mA

DIP Switch Settings			
1	2	3	4
On	On	----	----

GF disabled

FIGURE 7. DIP Switch GFEP Threshold Settings

### DIP Switch Settings HLT

DIP Switch Settings			
1	2	3	4
----	----	Off	----

Slab Regulating Temp. Sensor

DIP Switch Settings			
1	2	3	4
----	----	On	----

Ambient Air Sensor

FIGURE 8. DIP Switch Settings for High Limit Thermostat

## APS-3C LINE CONNECTIONS

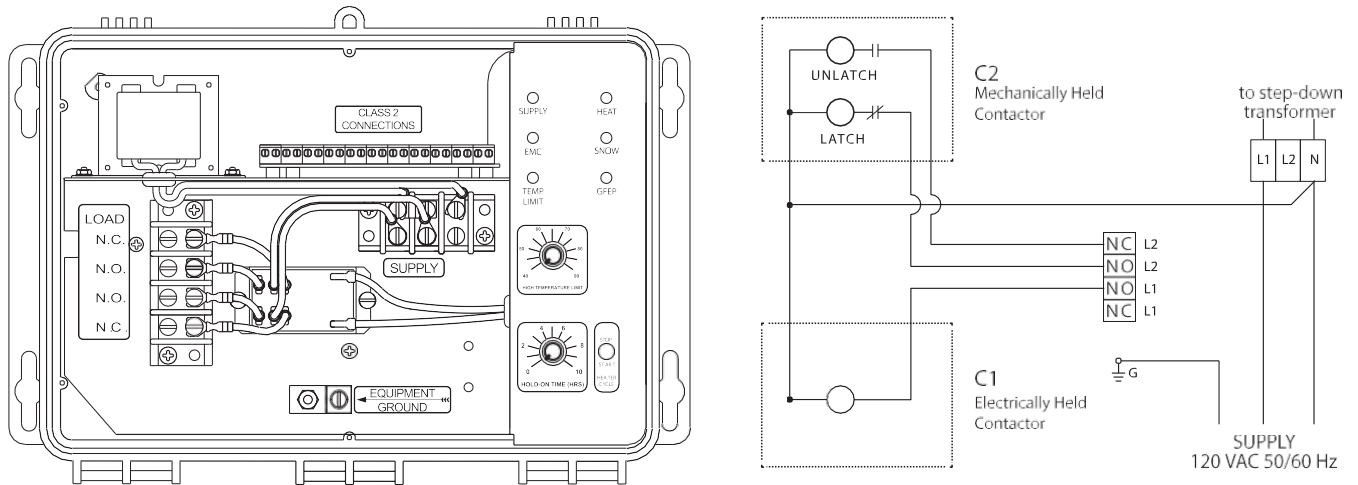

FIGURE 9. APS-3C: Operating Mechanically-Held and Electrically-Held Contactors

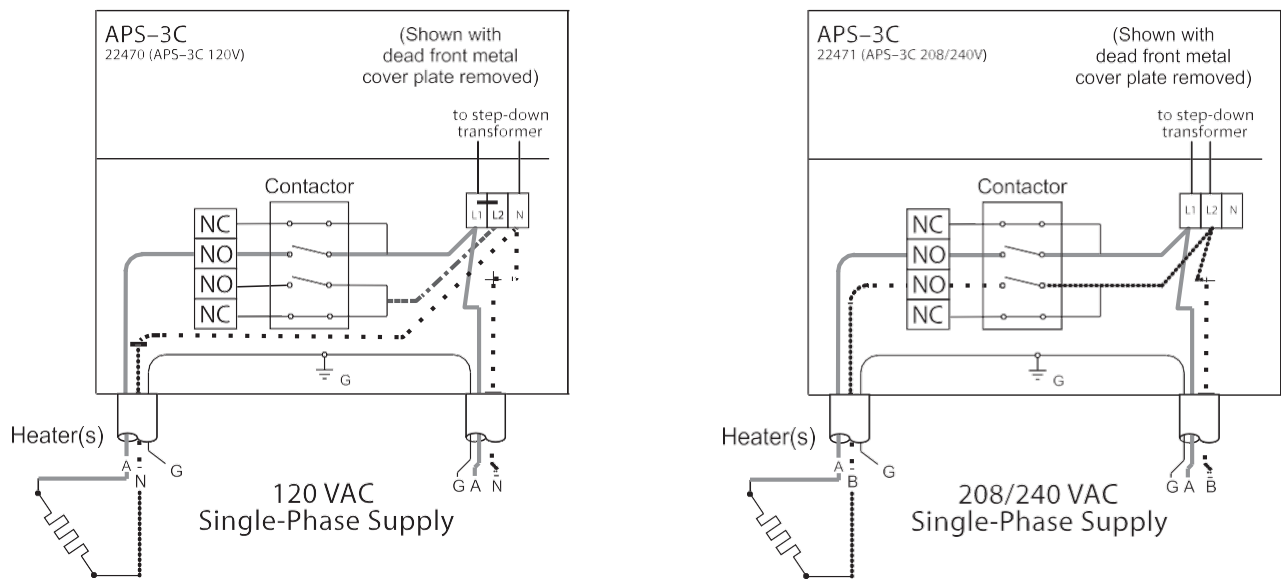

FIGURE 10. APS-3C: 120 VAC and 240 VAC Wiring to Heaters.

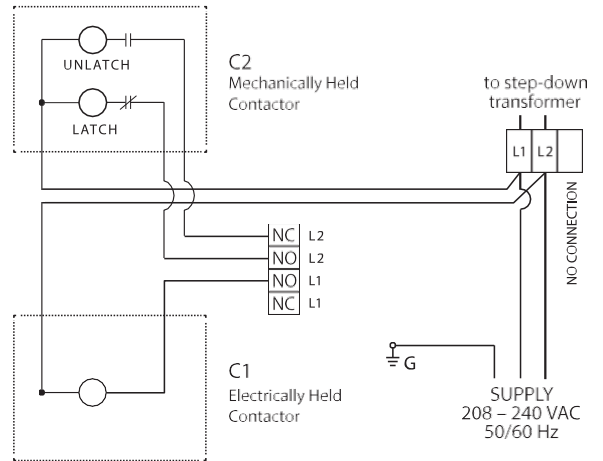
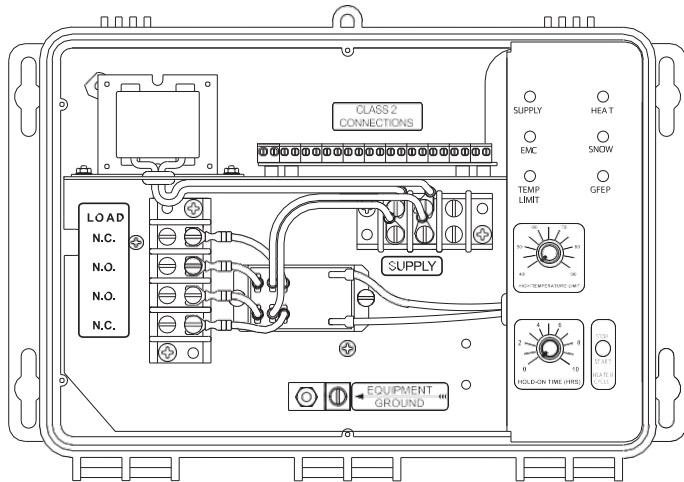
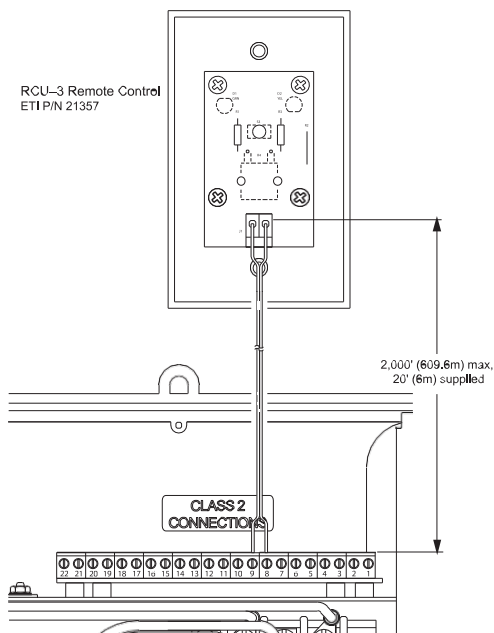

FIGURE 11. 240 VAC APS-3C Operating Mechanically-Held and Electrically-Held Contactors

## APS-3C & REMOTE CONNECTIONS

FIGURE 16. APS-3C & RCU-3 Remote Connection Between Pins 8 and 9.



## COMMUNICATIONS CONNECTIONS

FIGURE 19. APS-3C Sensor Connections.

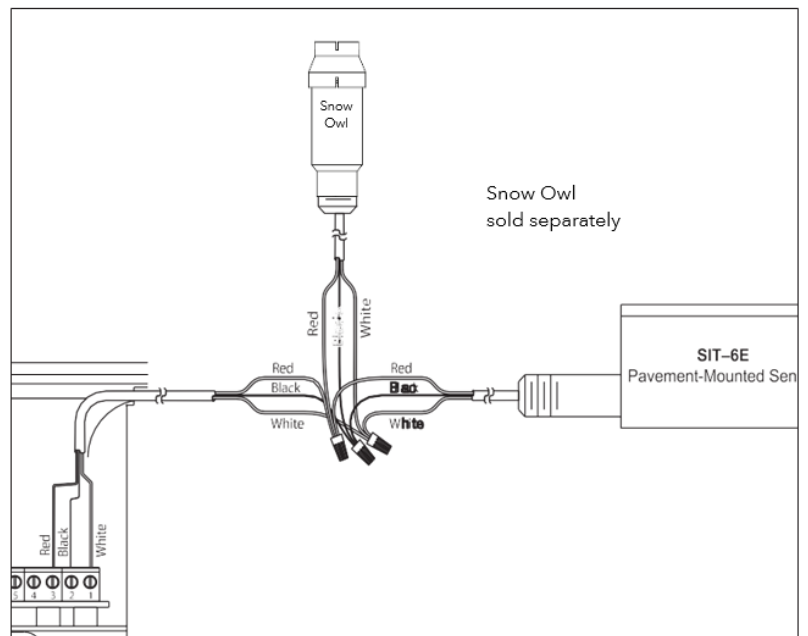

**BAS – BUILDING AUTOMATION SYSTEM MANAGEMENT COMPUTER**

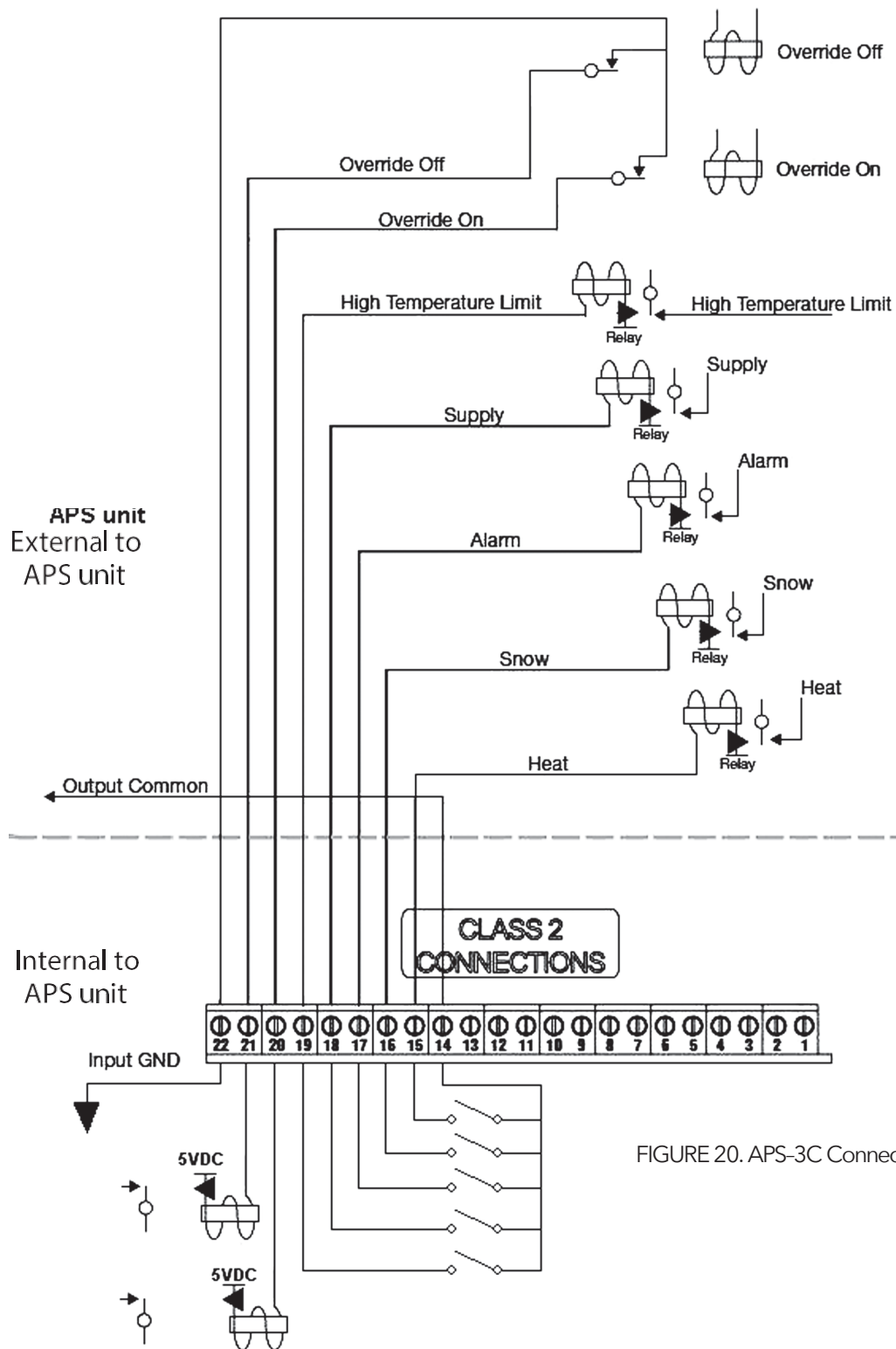

FIGURE 20. APS-3C Connections.

## INTERFACE BOARD CONNECTIONS

PIN #	CONNECTION
1	Sensor Connection (White wire)
2	Sensor Connection (Black wire - Gnd)
3	Sensor Connection (Red wire =+24VDC)
4	Satellite Panel Connection
5	Satellite Panel Connection
6	Satellite Panel Connection
7	Satellite Panel Connection
8	RCU-3/RCU-4 Connection
9	RCU-3/RCU-4 Connection
10	Thermistor Connection
11	Thermistor Connection

PIN #	CONNECTION
12	Electrician's DVM
13	Electrician's DVM
14	Output Common
15	Heat
16	Snow
17	Alarm
18	Supply
19	High Temperature Limit
20	Override On
21	Override Off
22	Close Override On/Off Circuit

## ORDERING INFORMATION

### Order # Description

22470	APS-3C Control Panel, 120 VAC
22471	APS-3C Control Panel, 208/240 VAC

### Accessories

21357	RCU-3 Remote Control (Optional; APS-3C only)
-------	--

25076	Temperature Sensor w/ 20 (6m) lead (Qty 1 included)
-------	---

### Snow/Ice Sensors (Not Included)

25516	SNOWOWLAerial Snow Sensor
11351	GIT-1 Gutter Ice Sensor
24219	SIT-6E Pavement Mounted Snow/Ice Sensor
23832	Pavement Sensor Housing

## CONTACTING CUSTOMER SERVICE

For assistance, contact Customer Service. Office hours are from 8:00 AM until 5:00 PM ET.

**Email:** [info@networketi.com](mailto:info@networketi.com)

**Web:** [networketi.com](http://networketi.com) **Mail:**

ETI

1850 North Sheridan Street  
South Bend, IN 46628

## LIMITED WARRANTY

ETI's two year limited warranty covering defects in workmanship and materials applies. Contact Customer Service for complete warranty information.

## DISCLAIMER

ETI makes no representations or warranties, either expressed or implied, with respect to the contents of this publication or the products that it describes, and specifically disclaims any implied warranties of merchantability or fitness for any particular purpose. ETI reserves the right to revise this publication, and to make changes and improvements to the products described in this publication, without the obligation of ETI to notify any person or organization of such revisions, changes or improvements.

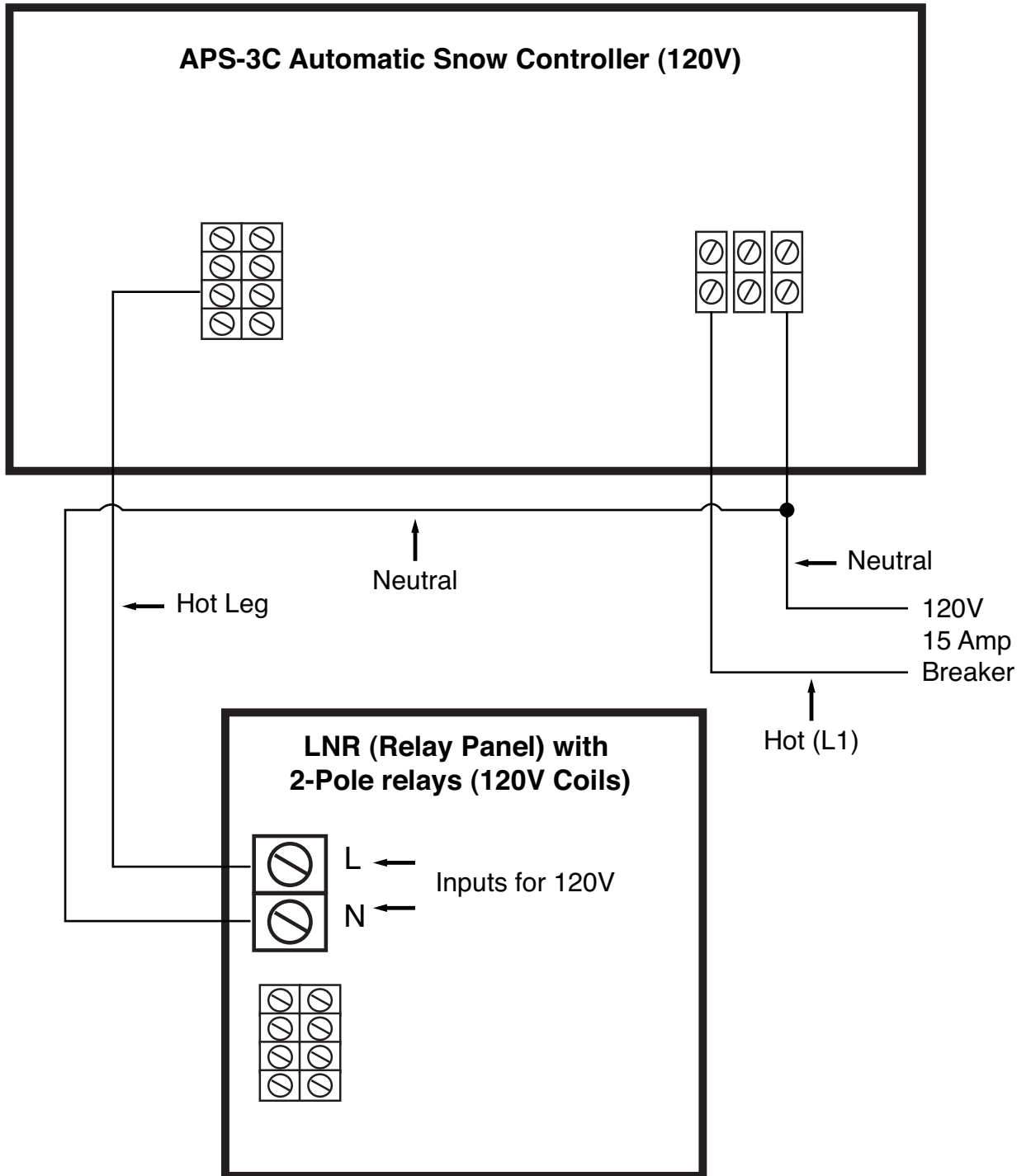

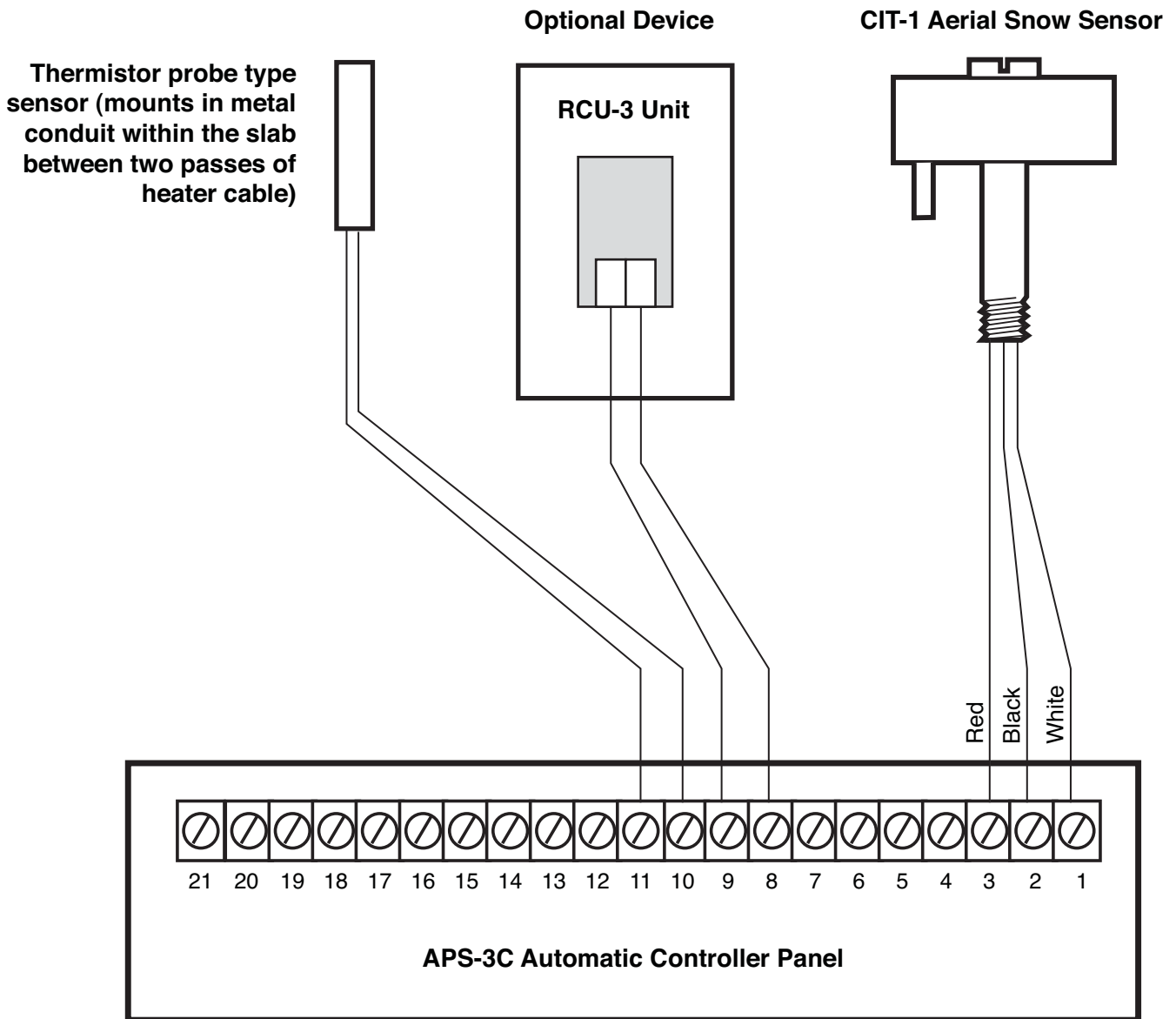

## **Important Notice for Québec Consumers:**

WarmlyYours does not provide repair services for this product. The only replacement parts available are splice kits for snow melting cables and mats; no spare parts are available for snow melting controls. If your snow melting system (cables, mats, or controls) fails within the warranty period, we will replace the entire unit according to our warranty policy. Our technical support team is available 24/7 by phone for installation and troubleshooting assistance. For full details, see our Return Policy. This notice is provided in accordance with Québec's Consumer Protection Act, section 39 (as amended in 2025).

## **Avis important pour les consommateurs du Québec:**

WarmlyYours n'offre pas de services de réparation pour ce produit. Les seules pièces de rechange disponibles sont les kits de raccordement (splice kits) pour les câbles et les tapis de déglçage ; aucune pièce de rechange n'est offerte pour les contrôleurs (snow melting controls). Si votre système de déglçage (câbles, tapis ou contrôleurs) tombe en panne pendant la période de garantie, nous remplacerons l'unité complète conformément à notre politique de garantie. Notre équipe d'assistance technique est disponible 24h/24 et 7j/7 par téléphone pour toute aide à l'installation ou au dépannage. Pour plus de détails, consultez notre politique de retour. Cet avis est fourni conformément à la Loi sur la protection du consommateur du Québec, article 39 (telle qu'amendée en 2025).