

Items needed:

1) A Splice Kit



1 - 14 - 16 AWG
Uninsulated butt
connector.
FASTENAL
P/N: 58615



2 - 20 - 18 AWG
Sealed Crimp +
Solder connectors
FASTENAL
P/N: 07009714



1 - 3/8" x 6" Flexible, Adhesive-Lined Heat
Shrink Tube. FASTENAL P/N: 0714596

2) Tools

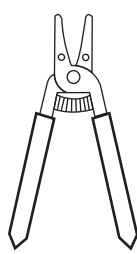

Wire Strippers



Crimping Tool



Butane Torch



Hot Air Pistol

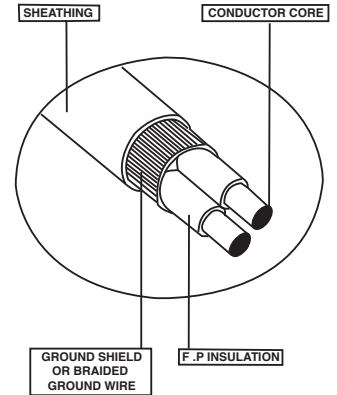

Step 1 - Determine where the damage is and make a clean cut through the wire.

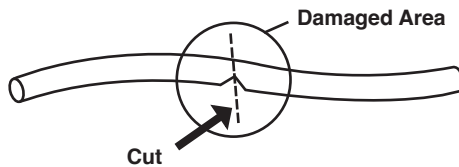

Step 2 - Using wire strippers, strip 1" of the outer insulation from both cables.

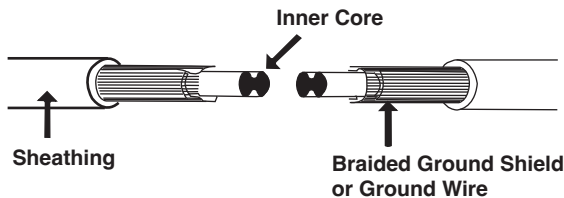

Step 3 - Separate the braided sheath wire or ground wire from the inner layer of insulation.

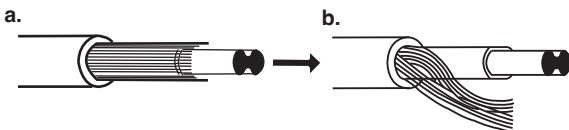

Step 4 - Shorten one inner conductor wire of both the cables to 1/2". Do not shorten ground wire.

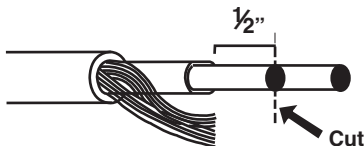

Step 5 - Place heat shrink tube over one side of the cable & then insert the inner conductor wires into each side of the crimp-on connector.

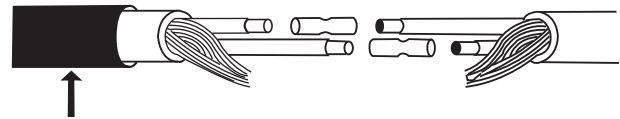

3/8" Heat Shrink Tube

Step 6 - Compress the crimp-on connector on each side using crimp tool and overlap both braided sheath wires and connect them with the uninsulated butt connector connector. Using a butane torch, carefully heat crimp connectors to seal crimp and melt solder.

Heat Connector with Butane Torch or Hot Air Pistol

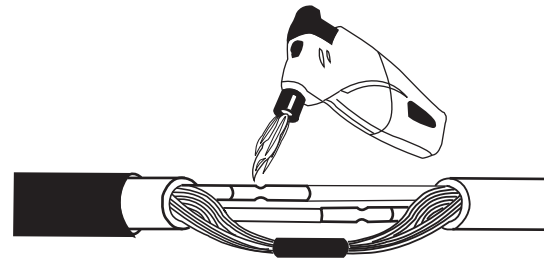

Uninsulated Butt Connector

Step 7 - Slide the heat shrink tube over the completed joint and shrink it with a hot air pistol. Do not use a naked flame. Verify sealant flow at both ends of the tube. There should be clear glue at each end of the tube. This will ensure a waterproof seal.

